

ALIMOS 5

4 THEOTOKI str., Pani

apartment
D.3



ALIMOS 5

4 THEOTOKI str., Pani

apartment D.3
93.50 m²

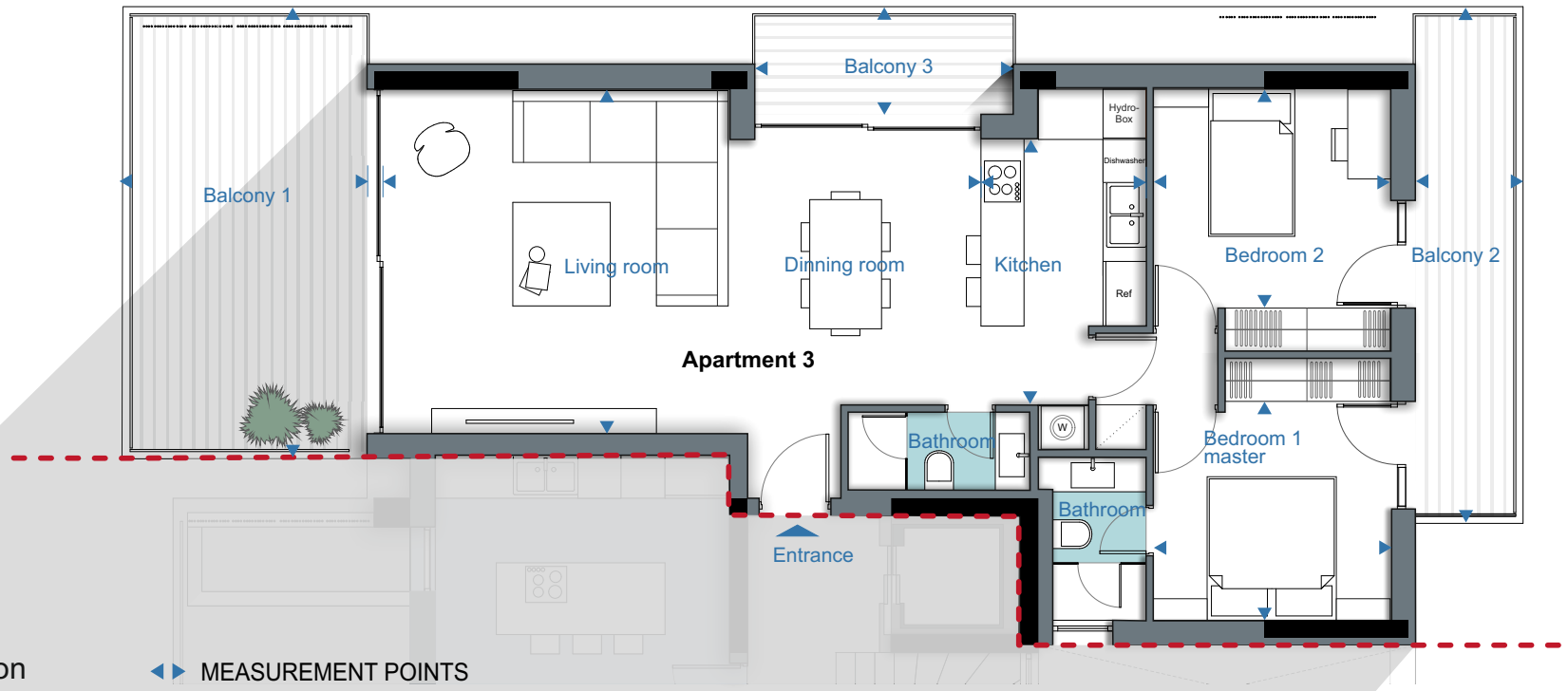

D.3 Apartment is situated on the **2nd floor** and has an area of **93.50 m²**.

MEASUREMENT POINTS

Living room - Dining room
8.35m x 4.80m

Kitchen
2.30m x 3.70m

Bedroom 1 (master)
3.40m x 3.00m

Bedroom 2
3.40m x 3.10m

Balcony 1
3.40m x 6.30m

Balcony 2
1.50m x 7.20m

Balcony 3
3.15m x 1.75m

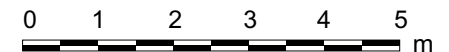
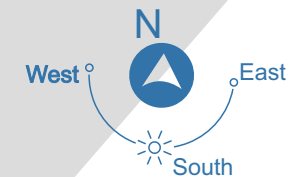

ALIMOS 5

4 THEOTOKI str., Pani

apartment **D.3**

93.50 m²

Apartment D.3 has on the **basement**:

Storage room 3 = **8.30 m²**

One parking spot, **P.10**

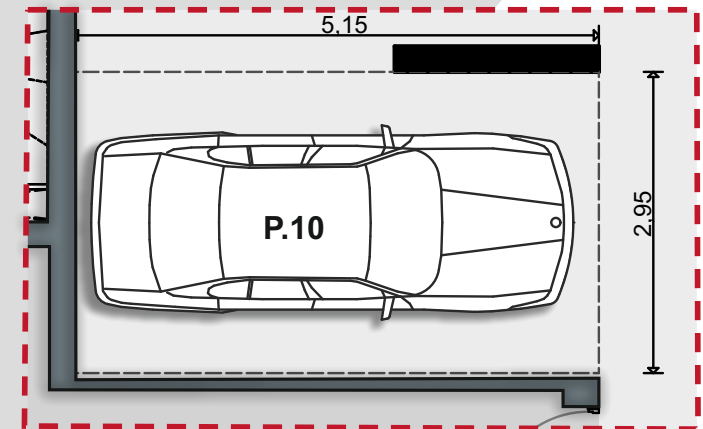
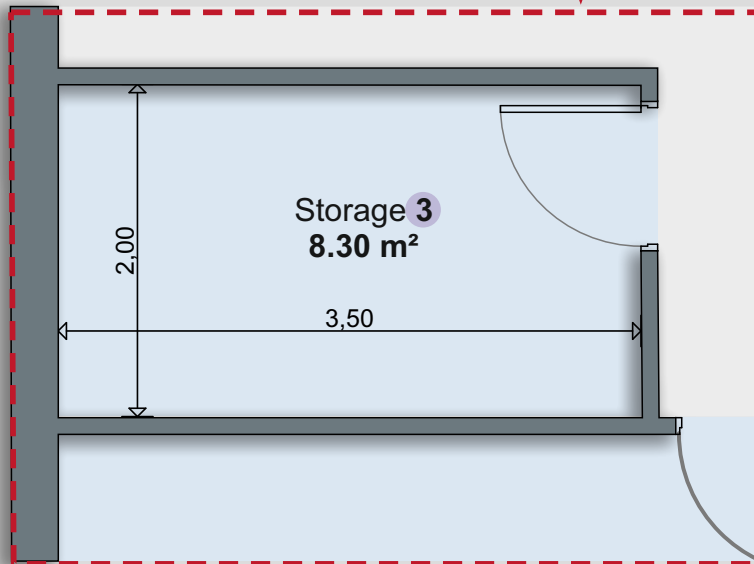
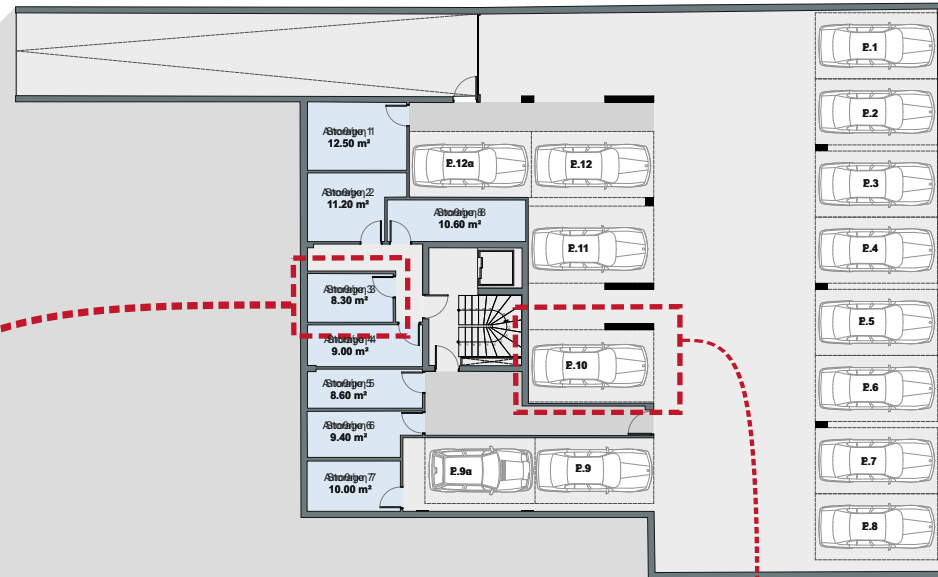

ALIMOS 5

4 THEOTOKI str., Pani

apartment **D.3**

93.50 m²

RENDERINGS



ALIMOS 5

4 THEOTOKI str., Pani

apartment D.3

93.50 m²

RENDERINGS

