

ALIMOS 5

4 THEOTOKI str., PANI

apartment
D.5



ALIMOS 5

4 THEOTOKI str., Pani

apartment **D.5**
93.50 m²

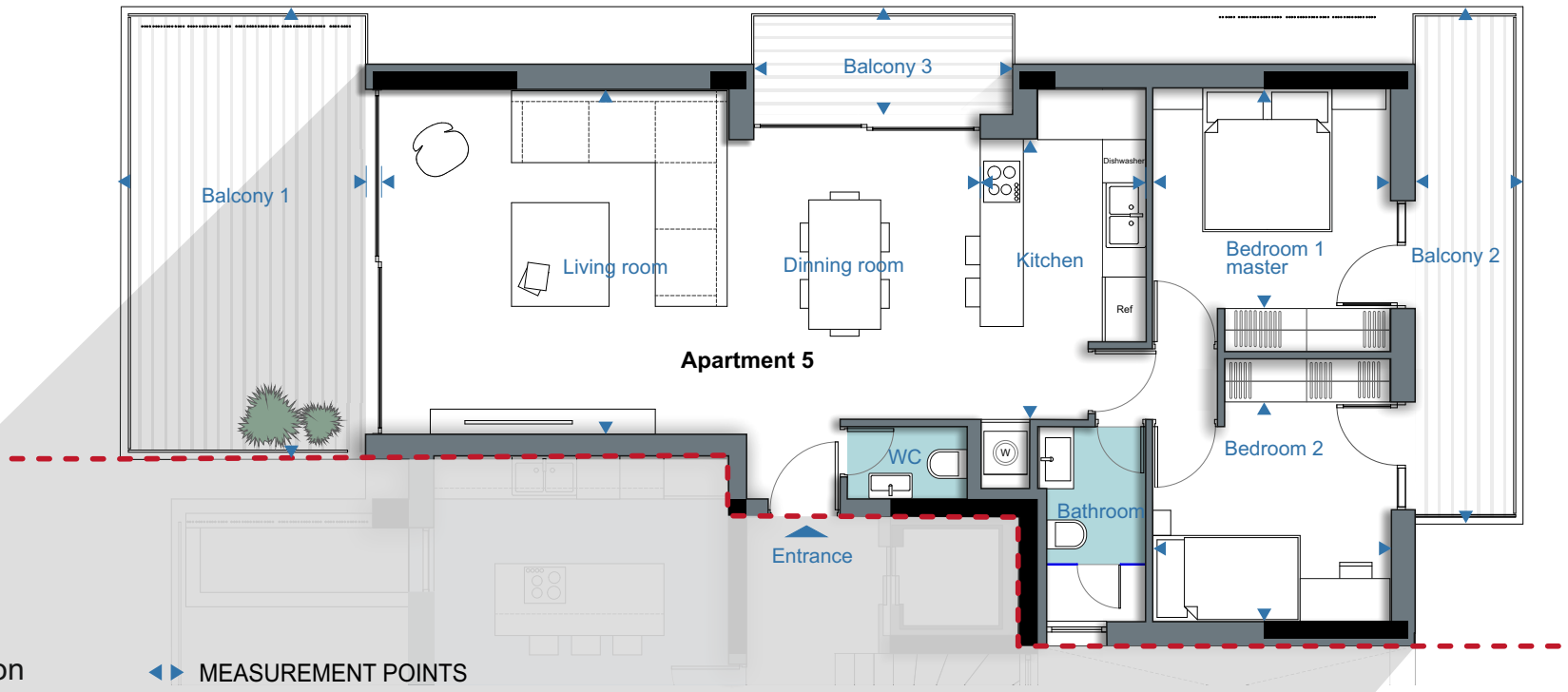

D.5 Apartment is situated on the **3rd floor** and has an area of **93.50 m²**.

◀▶ MEASUREMENT POINTS

Living room - Dining room
8.35m x 4.80m

Kitchen
2.30m x 3.70m

Bedroom 1 (master)
3.40m x 3.00m

Bedroom 2
3.40m x 2.95m

Balcony 1
3.40m x 6.30m

Balcony 2
1.50m x 7.20m

Balcony 3
3.15m x 1.75m

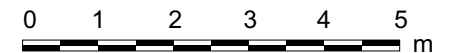
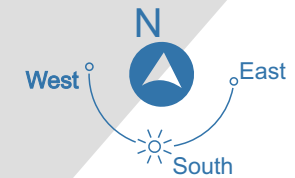

ALIMOS 5

4 THEOTOKI str., Pani

apartment **D.5**

93.50 m²

Apartment D.5 has on the **basement**:

Storage room 5 = **8.60 m²**

One parking spot, **P.11**

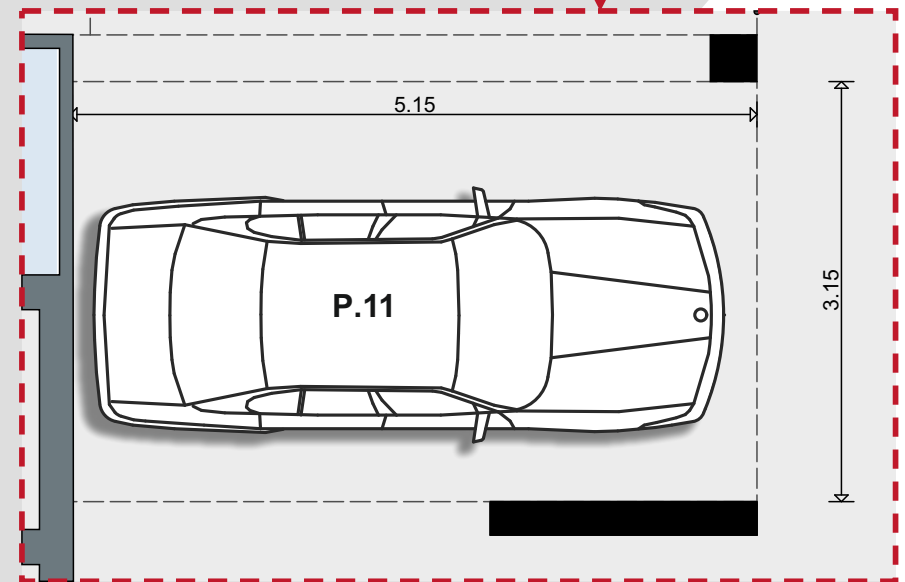
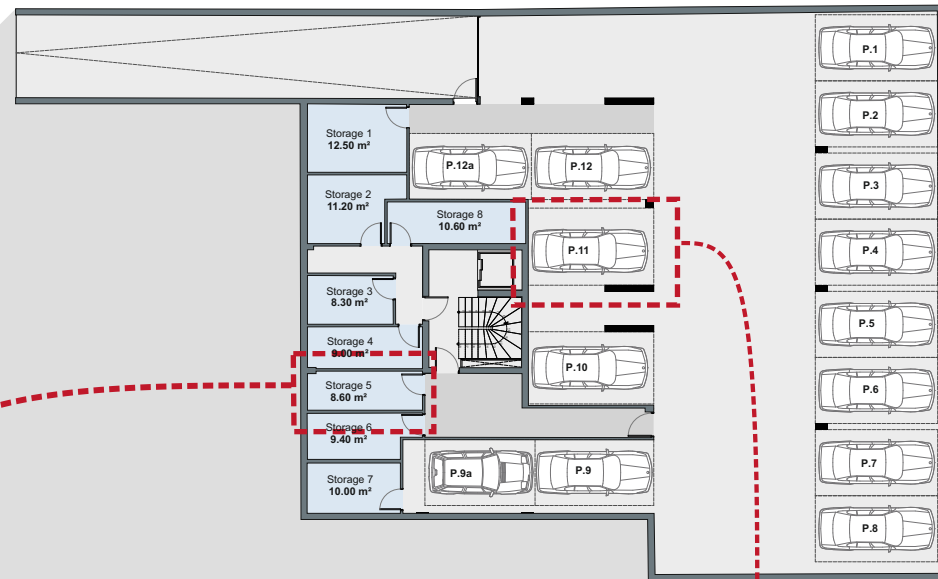
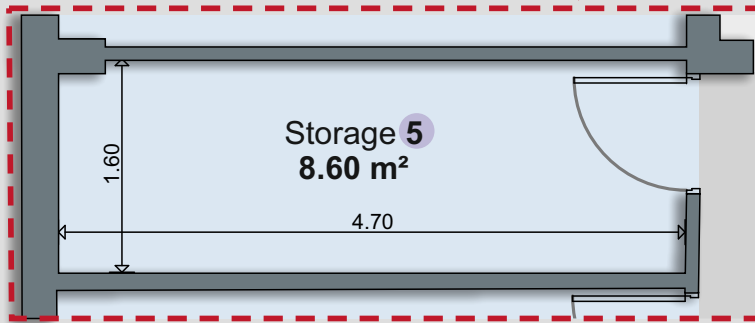

ALIMOS 5

4 THEOTOKI str., Pani

apartment D.5

93.50m²

RENDERINGS



ALIMOS 5

4 THEOTOKI str., Pani

apartment D.5

93.50m²

RENDERINGS

