

# NEA SMYRNI 2

nr. 48 MYKALIS str.

FACADE FROM MYKALIS str

Apartment

**D.4**

50,50 m<sup>2</sup>

2nd floor



# NEA SMYRNI 2

nr. 48 MYKALIS str.

2nd FLOOR

Apartment

## D.4

50,50 m<sup>2</sup>

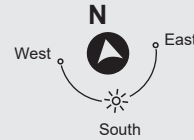

Mykalis str.

Characteristics	
Bedrooms	1
Baths	1
Total Aeria	50,50 m <sup>2</sup>
Balcony (total)	19,00 m <sup>2</sup>
Parking spot	P.7
Home storage	N° 3 = 8,46 m <sup>2</sup>

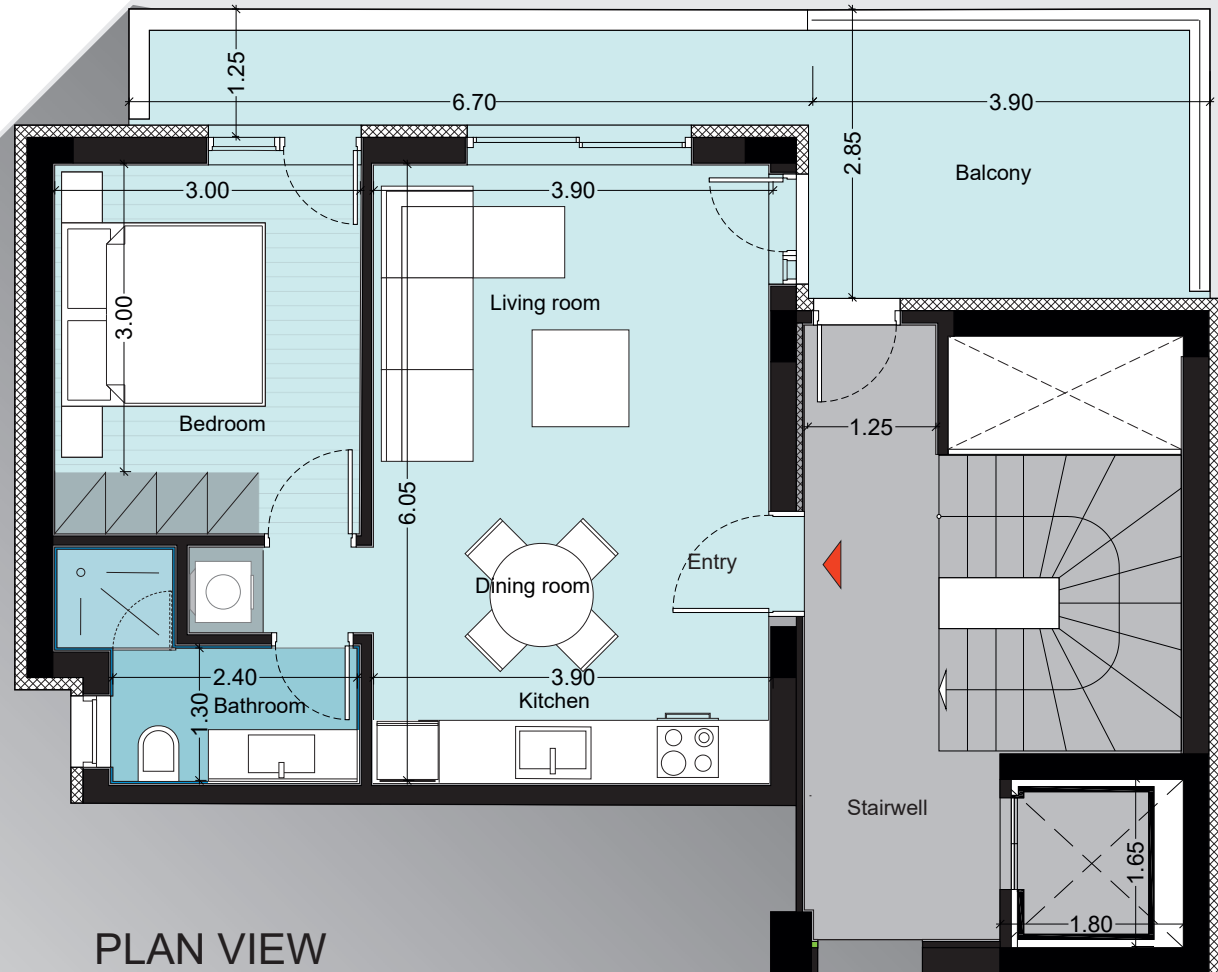

PLAN VIEW

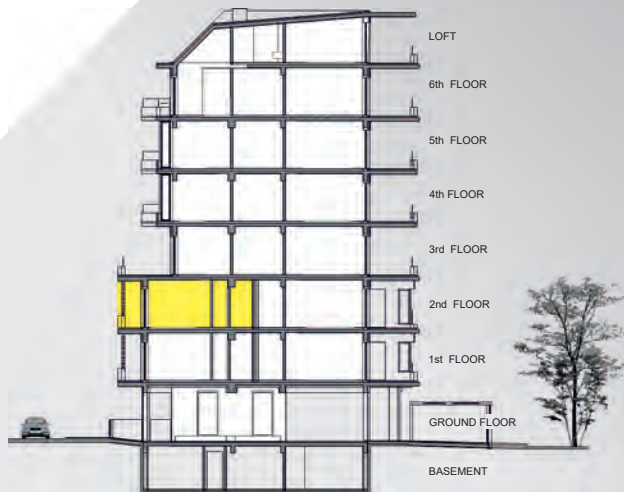

# NEA SMYRNI 2

nr. 48 MYKALIS str.

GROUND FLOOR

Apartment

## D.4

50,50 m<sup>2</sup>

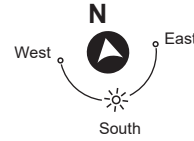

Characteristics	
Bedrooms	1
Baths	1
Total Aeria	50,50 m <sup>2</sup>
Balcony (total)	19,00 m <sup>2</sup>
Parking spot	P.7
Home storage	N° 3 = 8,46 m <sup>2</sup>

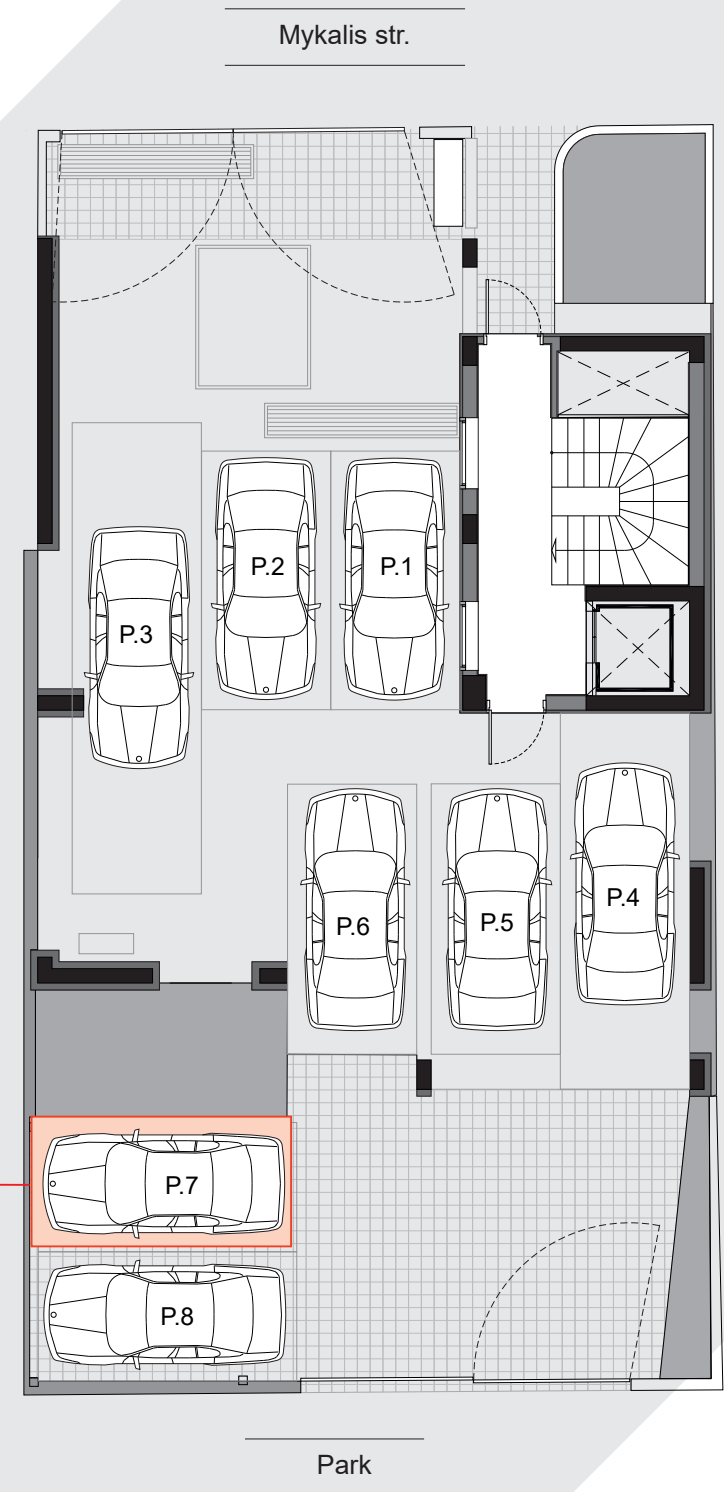
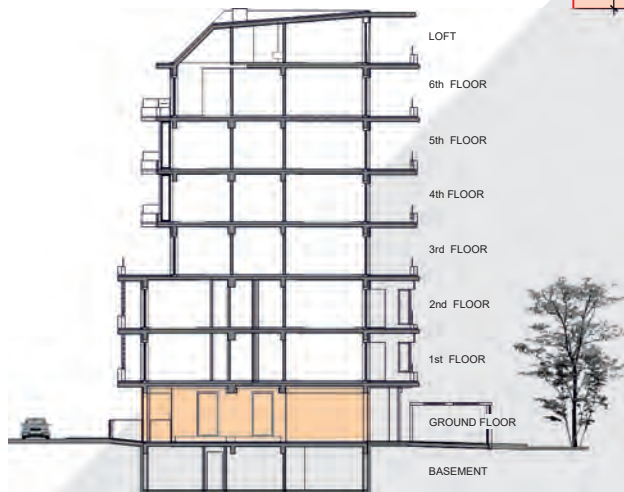
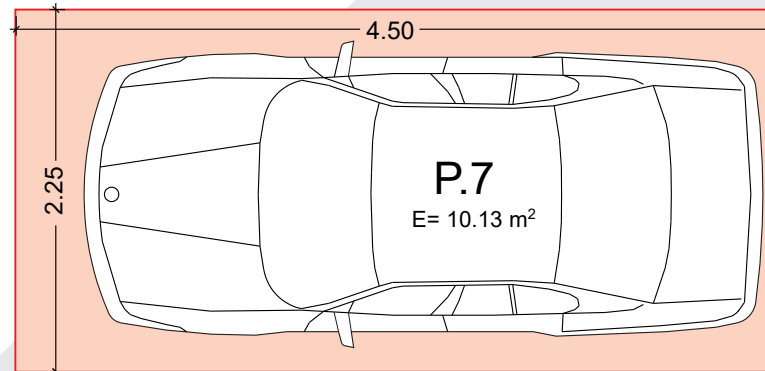

# NEA SMYRNI 2

nr. 48 MYKALIS str.

BASEMENT

Apartment

## D.4

50,50 m<sup>2</sup>

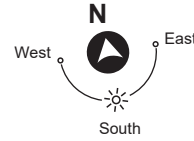

Characteristics	
Bedrooms	1
Baths	1
Total Aeria	50,50 m <sup>2</sup>
Balcony (total)	19,00 m <sup>2</sup>
Parking spot	P.7
Home storage	N° 3 = 8,46 m <sup>2</sup>

